

TGA *Supersport*



Supersport SE (all models) Operating Instructions and Owner's Handbook ►



CONTENTS

1. INTRODUCTION	2
2. ASSEMBLY	3
3. PREPARE THE SUPERSPORT FOR FIRST USE.....	4
4. THE CONTROLS AND INSTRUMENT PANEL.....	4
5. SEAT ADJUSTMENT	5
6. DRIVING.....	6
7. TRANSPORTING SUPERSPORT	7
8. PARKING BRAKE RELEASE.....	7
9. SAFETY OVERLOAD SWITCH.....	7
10. TIPS, CAUTIONS, PROBLEMS AND ADDITIONAL FEATURES	7
11. BATTERY CHARGING.....	8
12. A GUIDE TO SAFE AND LASTING BATTERIES.....	8
13. MAINTENANCE.....	9
14. TROUBLE SHOOTING.....	10
15. TECHNICAL SPECIFICATION	11
16. WARRANTY	11
17. SAFE DRIVING TIPS FOR SCOOTER USERS	12

1. INTRODUCTION

The Supersport – Outdoor Powered Scooter: Thank you for purchasing from TGA. We hope your Supersport will bring much freedom and pleasure to your life.

This handbook provides important information on the most common operational and maintenance concerns that the user should be familiar with. It is very important that the user is familiar with the driving technique and is able to operate the controls competently before venturing far from where there is assistance.

The handbook will draw your attention to important safety related issues by **Care! Warning** Labeling. Keep this handbook for future referral.

Care! Warning

- * Do not ride your Supersport without fully reading and understanding this instruction manual first.
- * Do not exceed the maximum gradient/slope of 12°.
- * Do not carry passengers (except vehicles purposely designed for this use on private land) or exceed the maximum carrying weight (see Technical Specifications).
- * Do not get on or off your Supersport unless it is switched off.
- * Do not switch your Supersport on with the speed control lever depressed.
- * Do not back your Supersport into uneven inclines or surfaces. Be cautious when traversing slopes.
- * Do not drive your Supersport in a confined space unless the speed adjustment is set to low.
- * Do not turn suddenly at full speed, especially on uneven or hilly ground. Failure to observe this may result in tipping of the scooter.
- * Do not drive your Supersport unless the seat is locked into the driving position.
- * Do not drive your Supersport over deep, soft terrain (e.g. soft dirt, deep grass, loose gravel).
- * Do not operate your scooter when under the influence of alcohol or certain drugs, which may impair your safety.
- * Do not climb or descend curbs that exceed the Supersport's capability.
- * Do not turn when negotiating curbs. Always approach curbs at low speed and straight.
- * Always stop fully before changing direction (forward or reverse).
- * Always keep your feet on the vehicle when driving.
- * Always proceed carefully while riding your scooter, especially as you approach the downgrade of a ramp or hill.
- * Always proceed carefully while riding on uneven surfaces.
- * Do not sit on your Supersport while being transported in a moving vehicle. Always restrain the scooter so that it cannot move in the vehicle and transfer yourself to a vehicle seat.
- * Do not drive your Supersport through deep water or clean with a high pressure hose.
- * Never attempt to freewheel down a slope as all braking will be lost.
- * Safe driving tips for scooter users have been printed in the back of this manual. For your own safety and that of others please ensure that you thoroughly read and understand this and in addition always obey the rules of the road.

Intended Purpose

The Supersport is intended for outdoor use and is fitted with large wheels making it ideal for rough terrain and cross country as well as normal use. It is capable of climbing slopes up to 21% (see technical specification) and negotiating obstacles up to 12cm. Care must be taken when using in these conditions.

Pavement Use

The speed of the Supersport is dependant on the weight of the occupant, incline and the type of surface. Tested with a weight of 18 stone (114.55kg) the Supersport had a speed of 7.5/8mph on the flat, on high speed setting. When used on the pavement, the UK law limits the speed to 4mph. For pavement use make sure 4mph is selected, and drive with care.

2. ASSEMBLY (WHERE NECESSARY)

The Supersport was pre-delivery inspected and tested prior to dispatch. The batteries may have been disconnected for delivery purposes only.

Remove all the items from the carton and strip the protective packaging materials off each item. Returns are only accepted when the product is shipped in the original cartons with the original packing material installed.

Supersport will have had the front wheel and the seat removed. Replace the front wheel and mudguard into the forks using the components supplied. Ensure the wheel nuts are securely tightened.

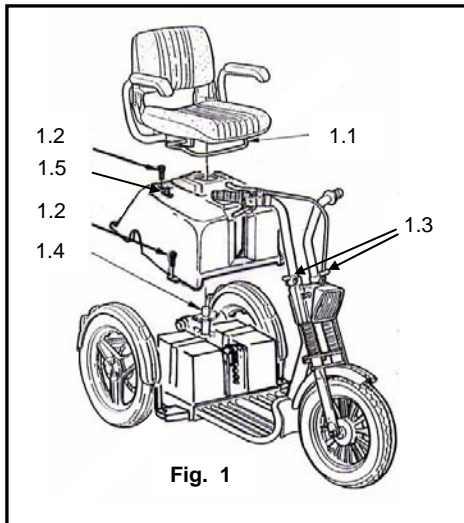

Fig. 1

Removal and Replacement of Deluxe seat – To remove seat, release the seat locking lever, at front of seat, and turn seat through 180° so that it faces to the rear. Now lift seat straight up and out. Replacing the seat is just a reversal of the above.

Removal and Replacement of Standard seat – To remove seat release the seat locking lever at front of seat, fig 1.1, and lift the seat straight up. Replacing the seat is just a reversal of the above.

Rear Cover Removal – Remove seat, then unscrew the four black fixing screws located at the top rear and side of the cover (fig 1.2). Remove cover. Replacement is just a reversal of the above, ensuring the cover locates correctly. If your Supersport is fitted with the rear basket then there will be a further two fixing screws holding the basket to the rear bumper which will need to be removed.

Rear Cover Removal (wide and extra wide seat) –

Release the seat locking lever found at the middle front under the seat fig 2 and carefully tilt the seat back. Remove cover as described in previous paragraph.

Handlebars – These are individually adjustable for height and angle. Release the securing levers fig 1.3 and set the handlebars to your preferred height and angle. Re-tighten securing levers. The controls are on the right hand bar, however left hand controls are available. If you have the Supersport with extra wide seat, one handlebar will be shorter than the other, to allow for offset driving position.

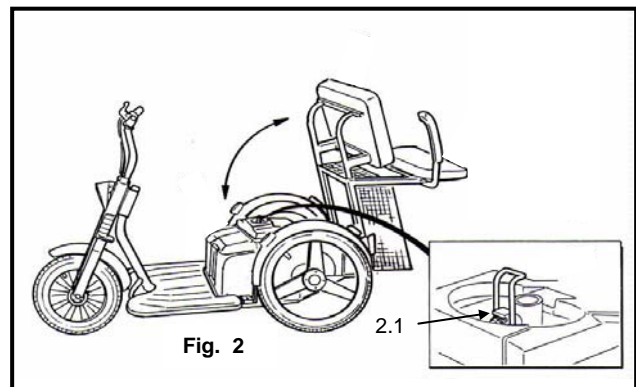

Fig. 2

Batteries – For safety in transit the main supply leads may have been disconnected from the batteries. The black lead would have been disconnected from one battery and the red lead from the other. These will be taped to the batteries in an obvious position as will the fixing bolts. Simply reconnect the leads ensuring the bolts are correctly tightened.

3. PREPARE THE SUPERSPORT FOR FIRST USE

If you receive your Supersport packaged and it has to be assembled see the section covering Assembly. The batteries will require charging - refer to Charging the Supersport for details.

Care! Warning

The Supersport is easy to drive but it is essential that you familiarise yourself with the controls and learn to drive it in a safe area with sufficient room to maneuver for your safety and that of others. The area should be free of obstacles and reasonably flat. Mark a practice course for straight line driving, turning in confined spaces, reversing and driving around obstacles.

4. THE CONTROLS AND INSTRUMENT PANEL

Figs 3-6 Provide details of the control system. Listed below are the various controls and their uses.

1. **Speed Control Levers** - The speed of Supersport is controlled by the red lever located on the right hand handlebar and shown in Fig 3.1. Always use the lever gently, remembering that the more you squeeze the lever in the quicker you will go. To stop simply release the lever, the braking is completely automatic and when the machine has stopped the parking brake will engage and stay on until the machine moves off again. You may have a machine that has been fitted with the following factory fitted option:-
a) L/H speed Control Lever - This is used exactly as described above and is fitted to the L/H handlebar instead of R/H

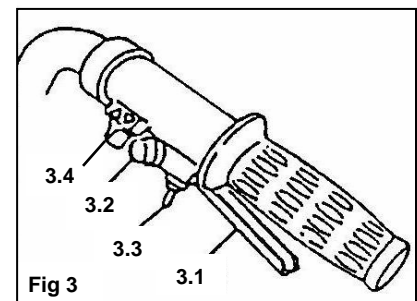

2. **Emergency Brake** - All braking on the Supersport is automatic and the emergency brake should never need to be used. It is only for emergency in the very unlikely event that the automatic braking fails. The lever is located on left handle bar (fig 4.1). If your machine has been fitted with the L/H speed control lever, then the emergency brake will be fitted to the R/H handlebar.

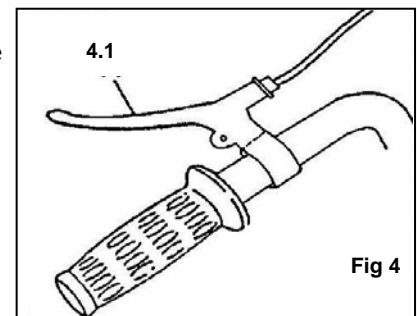

3. **Horn** - Button located on R/H side of handlebar (fig 3.2). The buzzer can also be configured to automatically sound when using driving in reverse (this function is deactivated as standard).

4. **Indicators** - Left and right hand located on the R/H handlebar. Push the switch in the same direction as you need to turn. To stop the indicators, return button to central location (fig 3.3).

5. **Hazard Warning Lights** - Operates all indicator lights together and for emergency use only. The button is located on the side of headlight. Press button to operate. Press again to switch off (fig 5.1).

6. **Head Light Switch** - This switches on front and rear lights, and located at fig 5.2. Lights will reduce range of scooter. Use only when necessary.

7. **Power On/Off Switch** - This has a removable key which should be taken out when machine not in use. When the key is inserted the switch has two positions, "off" where there will be no power to the machine and the parking brake will be engaged and "on" where the machine is ready for use (fig 5.4). If Supersport is inadvertently left switch on, after a certain period of time it will shut itself down to conserve battery. To restart, turn the key to off, wait a few seconds and turn on again.

8. **On Light** - Will come on green when the key is turned to on and Supersport ready for use (fig 6.1). This light is also used as a fault indicator and if it is flashing Red/Green it is showing the Supersport to either have a fault or the parking brake release lever has been activated.

9. **Forward/Reverse Switch** – Located on the RH handlebar (fig 3.4). Select your desired direction by pressing either side of switch as marked. When using reverse the top speed is automatically reduced and a warning buzzer will sound (please note the reverse buzzer is deactivated as standard). **WARNING** Always come to a complete stop before changing selector switch.

10. **Speed Selector Switch** – This is located on the LH side of headlamp (fig 5.3). It has two positions, 'up' is the high speed (approx 8 mph) and 'down' is the slow speed (approx 4mph). **CARE WARNING** – It is a legal requirement not to exceed 4 mph on footpaths or shopping areas. Always use the slow speed when driving inside buildings, crowded areas, sales, stately homes etc. Using the faster speed in these sort of conditions presents a serious danger both to yourself and people on foot. Don't forget these machines are very quiet and others may not be aware of your presence. The 8 mph speed is only legal for road or off road use. **ALWAYS COME TO A STOP BEFORE CHANGING SPEED.**

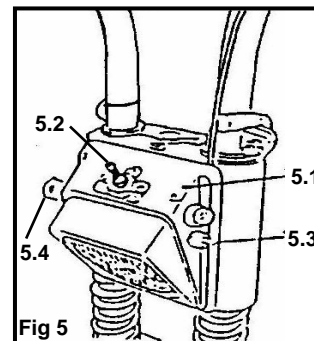

11. **Battery Condition Indicator (Fig 6)** – Located on top of the headlamp and indicates the capacity of the battery. When the indicator is as far to the right as possible shows the battery to be fully charged. It will gradually move across to the left as the battery power gets used. When it reaches the middle you should start thinking about recharging, and when it reaches the last 2 or 3 divisions it is important to get it on charge as soon as possible. At this point there may only be one or two miles left. It is impossible to be more specific than this as every rider and different types of terrain will achieve different results. It is important to only use Supersport on short runs to start with to explore the sort of range you will be achieving. Then when you are confident about range, start going on longer journeys.

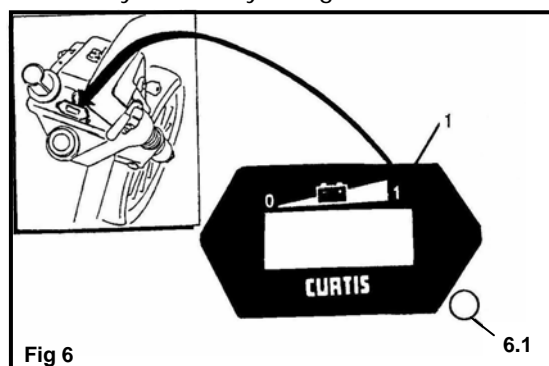

5. SEAT ADJUSTMENT (STANDARD SEAT)

1. For ease of entry and exit to Supersport the seat will swivel to the left or right. The lever is located at the front of the seat (fig 1.1). Make sure the seat locks in before either getting on or off, or driving.
2. Armrests can be raised or lowered allowing easier entry and exit.
3. The seat height is adjustable by altering the position of the seat stem. Remove the seat and rear cover and you will see the seat stem is held in its location by a single bolt. Remove the bolt and the seat stem can be adjusted up or down to any one of its fixing holes. Adjust to your preferred position and tighten bolt. Refit cover and seat (fig 1.4).

SEAT ADJUSTMENT (DELUXE SEAT)

1. For ease of entry and exit to Supersport the seat will swivel to the left or right. The lever is located at the front of the seat. Make sure the seat locks in before either getting on or off, or driving.
2. The seat adjustment lever located at the front of seat allows the seat to be adjusted forward or backward.
3. Backrest can be adjusted by releasing lever on LH side of seat.
4. Armrests can be raised or lowered allowing easier entry and exit.
5. Headrest can be made higher simply by pulling gently upward. To lower there is a small lever located on the top of the seat at the base of the left hand headrest support. Simply press the lever and adjust to preferred height.
6. The seat height is adjustable by altering the position of the seat stem. Remove the seat and rear cover and you will see the seat stem is held in its location by a single bolt. Remove the bolt and the seat stem can be adjusted up or down to any one of its fixing holes. Adjust to your preferred position and tighten bolt. Refit cover and seat (fig 1.4).

6. DRIVING

Before driving make sure that the Battery is fully charged, check that the tyres do not appear to be soft, see Maintenance section for details of monthly checks and tyre pressures. Check that the Key is switched OFF before entry. When comfortably sat, ensure that the seat lever has locked the seat secure. Ensure that the armrests are in the down position.

1. Set the Supersport speed to slow and switch on. Hold the handlebars with both hands and gently squeeze the right control lever to move the Supersport forward. The more you squeeze the lever, the faster you will go. Always come to a stop before changing H or L speeds, or forward and reverse.

2. Releasing the control lever automatically operates the brakes to slow down and stop. Once stopped, the parking brake will automatically come on.

3. Use the handlebars to steer.

4. To go backwards, select reverse and squeeze the right control lever again. The speed in reverse is reduced automatically for safety.

5. To negotiate from pavement to road, or road to pavement, you should try to find a suitable slope. The Supersport will mount, or go down kerbs 12cm high, but you should approach a kerb at right angles (90°). You should stop just short of the edge and:

- * If you are going up; select the high speed setting then drive until both front and back wheels are on the pavement, then immediately lower the speed.
- * If going down, proceed slowly on low setting until on the road, then switch to a suitable higher speed to cross the road safely.

6. The Supersport is suitable for road use BUT great care must be taken and at the maximum speed of 8 mph, you may present a hazard to other faster moving road users. (See safe driving tips at the rear of this manual.)

7. Watch your Battery Indicator. The distance you can travel depends on many factors, the more slopes, the less distance you can travel. We recommend that you gradually explore going further each day.

8. Should the battery "run out" before you get home there are two things you can do to avoid being stranded. Stopping and switching off the KEY for 5 – 10 minutes will allow the battery to "recover" a little power so that you can proceed further. You can attempt this a number of times. If you are unfortunate and cannot return to home under the battery power there is a "Free Wheel" device that will allow someone to push the Supersport home (see Parking Brake Release).

9. Range is influenced by many environmental conditions, hills will substantially decrease the range. Establish what you can obtain around your locality by gradually increasing the distance and checking the battery indicators at the end of each journey.

10. Reducing the speed will also reduce the power. For climbing obstacles or hills you will need to increase the speed setting to give the power and then control the speed with the levers.

Parking

1. Before leaving the scooter, switch the ignition off, the battery indicator will then go off. Remove the ON/OFF Key for security.

2. If the Supersport has been used in the Free Wheel mode (see Parking Brake Release), it is VERY IMPORTANT to re-engage the drive to ensure that the scooter brake is on before you alight.

3. Flip up the armrest to make it easier to alight from the Supersport, or swivel the seat through 90°.

7. TRANSPORTING SUPERSPORT – When transporting Supersport in a motor vehicle the height can be reduced by the removal of the seat the removal or lowering of the handlebars. Everything however must be securely strapped down including the scooter itself and anything removed from it. The user must never travel in a vehicle seated on Supersport but should transfer to a proper vehicle seat. CARE WARNING – All components are heavy, seek help if you think you may injure yourself when lifting.

8. PARKING BRAKE RELEASE – The Supersport is fitted with a manual brake release. This is located at the rear right hand top of the cover, just behind the seat, fig 1.5. There will be no power to drive Supersport when the brake is in the off position and when switched on the 'on' light will come on but will flash indicating a fault mode. Never release this lever when Supersport is on a slope.

9. SAFETY OVERLOAD SWITCH – The Supersport is protected electrically and electronically by 4 overload switches. They are designed to 'pop-out' should an overload or serious electronic fault occur. Possible examples that could cause the main overload switches to activate could be, steep or very long slope or high kerb causing overloading and overheating or possible accident damage.

Two of the switches cover the main drive whilst one covers the lighting circuit and the other the charging circuit. These are located at the front of the motor cover in the middle and directly behind your legs (fig 7.1). Should the main drive switches become activated for whatever reason they will cause a complete electrical shutdown and the parking brake will come on (fig 7.2). Switch off, allow a few minutes and push the button in to reset. If it will not reset, leave a few more minutes and try again. If it refuses to reset get in touch with your dealer. Never attempt to hold the button in by any other means. If the lights are not working or the machine will not charge, try the appropriate overload buttons. If they will not reset follow the instructions above (fig 7.3 and 7.4).

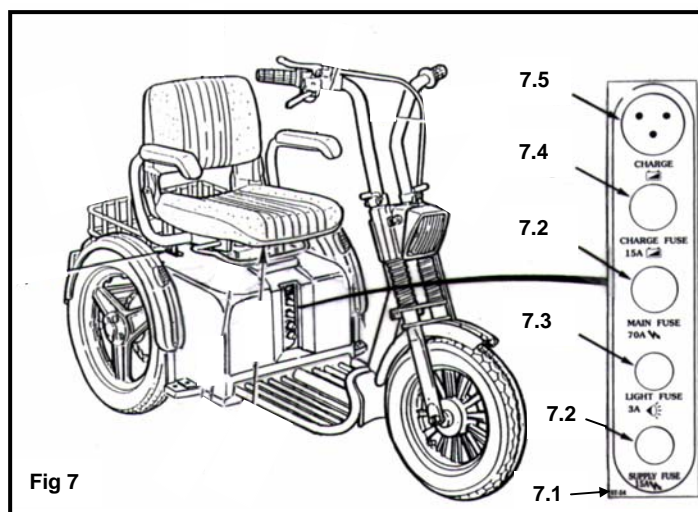

10. TIPS, CAUTIONS, PROBLEMS AND ADDITIONAL FEATURES

Stop Problems Before they Start - If you detect an unusual vibration or noise in the operation of your Supersport, try to determine the cause. Be sure the power is off before investigating. If you cannot discover the cause of a problem contact your dealer or TGA for help.

Airline Checking - Sealed Lead Acid Batteries are permitted on most aeroplanes. A sticker on the battery case states what they are. Airline personnel may insist on removing the battery cover to verify its contents. It is best to check with the airline before hand. An airline compliance certificate is available from TGA, however it is up to the discretion of the individual airline regarding the transportation of items on their planes.

Storage - Avoid storing your Supersport in locations with extreme heat or cold. A cool dry location is ideal if possible. The following steps will help keep rust and corrosion from impairing your scooters function and appearance. Turn the key to the off position. Clean all exterior surfaces, touch-up any damaged paint. Check and inflate the tyres to 35 PSI. Be sure the battery is fully charged before prolonged periods of storage and be sure to recharge every 6 weeks. Failure to comply may result in battery replacement.

11. BATTERY CHARGING

The battery charger supplied is special to your Supersport and so it may not be suitable for any other powered mobility product. Only use the charger supplied with your Supersport as other makes of chargers may permanently damage your batteries and would void the warranty.

To charge your batteries follow these simple steps.

1. Switch OFF your Supersport and remove the key.
2. Plug the charger lead into the socket located in the middle of the front of the rear cover, fig 7.5. Plugging the charger into Supersport automatically cuts all power to the electronics and the scooter cannot be driven.
3. Push the plug from the charger into a suitable wall outlet and switch on.
4. The red light will come on for "mains on" as will an amber light indicating the battery is charging. Green will light when the batteries are fully charged.
5. When the batteries reach their charged state, the charger will automatically stop charging. The lights will, however, still be on but the batteries cannot overcharge.
6. Although to get out of trouble the batteries can be put on charge for a short period of time, it is always best to go through a complete charge cycle each time. Excessive short period charging will be detrimental to battery life.
7. For the best results and to prolong battery life, try to run the battery down by at least 50% before recharging and in addition it is always best to go through a complete charge cycle each time.
8. Depending on the depth of the discharge, the minimum time taken to recharge serviceable batteries fully will vary up to 12 hours. Please note that this time may increase as batteries get older. During periods without use (perhaps during the winter) it is wise to charge the batteries every 4 to 6 weeks.
9. For the best results your batteries must be cycled for their first 10-15 charges. This means run them down as much as you safely can in use and then give them a full charge. They will not work at their best until this process has been carried out.

You will find that the distance that your Supersport can travel will gradually increase over the first few weeks of use as the batteries reach their optimum efficiency after approximately 12 cycles of discharge and recharge.

Care! Warning

- * Do not smoke or use a naked flame while your batteries are being charged.
- * Do not use the charger if it has received a sharp blow, been dropped or otherwise misused in any way. Take it to a qualified technician.
- * Do not dismantle the charger. This will void the warranty.
- * Do not leave charger plugged into your Supersport with charger switched off as this may discharge your batteries.
- * For a complete charge – Do not switch off, unplug or interrupt the recharge cycle until the charging cycle has completed.

12. A GUIDE TO SAFE AND LASTING BATTERIES

- * For longest life, your batteries should be recharged after reasonable use.
- * If your Supersport is not used for a period of time, a refreshing charge should be given every 4-6 weeks. Never leave your batteries in a discharged condition. This is particularly important to sealed batteries such as the type in your Supersport.
- * If your Supersport is to be stored away for some time, make sure the batteries are fully charged before storing. Fully charge the batteries before re-using it.
- * Every six months, check the connections on the batteries, making sure they are tight and clean.
- * Supersport is fitted with sealed maintenance free batteries especially designed for powered mobility. They do not require topping up and will not leak out even if batteries are inverted.

Batteries carry a limited warranty from the original manufacturer, which is subject to a stringent wear and tear clause. Any battery faults due to a defect by the original manufacturer will normally become obvious within the first two months. Any gradual deterioration in performance after this period is normally associated with fair wear and tear; misuse or accidental damage is not covered by the manufacturer's warranty.

13. MAINTENANCE

We recommend that the Supersport has an annual service and maintenance check by your Supersport Dealer or TGA Ltd. The following are weekly/monthly checks that will keep the machine in good running order.

- Do not apply oil or grease to any components. Sealed bearings and nylon bushes eliminate the need for lubrication.
- Keep all components clean and dry.
- Keep tyres inflated to 35 psi. Low tyre pressure will degrade performance so it is very important to check pressure frequently.
- Check tyres for wear. Replace as soon as there is any sign of excessive wear.
- The Supersport uses maintenance free batteries, they are leak-proof regardless of position. Charging the battery is the only maintenance required (refer to charging instructions). DO NOT leave the batteries flat, charge every 4-6 weeks if the Supersport is being stored and not used.
- Check the electrical cable connectors are fully home and secure.
- Battery Replacement is dependent upon use, the batteries generally last up to 3 years. When batteries loose power too quickly, it is likely they are due for replacement. If there is no dealer in your area, you may want to change the batteries yourself. Order batteries direct from TGA Ltd. Installation instructions are included with the replacement batteries.
- Repairs relating to electrical or mechanical components should be performed by your Supersport dealer only.

Seat Upholstery: A damp cloth and a little soap will keep your seat, and backrest looking good. Do not use abrasive cleaners as this will damage the coating. Upholstery can be damaged by chemical cleaners. Ultraviolet light can also reduce the life of the upholstery coating material. This is a normal ageing process and cannot be guaranteed (see exclusion in the Warranty Terms section).

Bodywork: The bodywork on your Supersport can be lightly washed with clean soapy water. Car polish can be used to keep the paint and bodywork in pristine condition. Do not use abrasive cleaners or strong detergents as this will fade the colour.

CAUTION: Do not hose down your Supersport. Water could be forced into the electronics and cause permanent damage.

DO NOT store your Supersport in damp conditions. This may affect the electronics if left for very long periods of time.

Electronics: Servicing of the drive electronics and charger should only be carried out by your local TGA service dealer. These units are sealed and should not be opened. **BROKEN SEALS WILL VOID YOUR WARRANTY.**

DO NOT operate your Supersport in extreme weather conditions i.e. very heavy rain. **DO NOT** drive through deep water. This could damage the main electronic controller or the electronics.

Motor Brakes: If the motor brakes are functioning correctly, you will not be able to push your machine when it is switched off or switched on with the speed control throttle in the neutral position.

If your machine can be pushed when as described above, the motor brake(s) may be faulty. **Do not use the scooter and contact your TGA dealer.**

SAFETY NOTE: For your own safety, we recommend that you check the function of your brakes prior to every journey.

Driving Brake: When you drive your Supersport and let go of the speed control throttle, it should reduce speed very quickly. If you notice a change in the normal driving/slowing condition and your Supersport does not slow down quickly **please do not use your machine and contact your TGA dealer**

Batteries: Keep your batteries well charged (see Battery Charging section). Keep batteries clean and in a dry frost-proof place. Keep battery terminals tight.

IMPORTANT: It is not possible to predict the life expectancy of your batteries. This is mainly due to different workloads a battery can be subjected to.

Some Supersport users will use their scooter every day and for long periods of time. Their batteries will receive a near total and regular discharge and the life of their batteries will be short (12 months or less in some cases). Other Supersport users will use their vehicles less frequently, putting their batteries through a less demanding discharge lifestyle. These batteries will probably have a longer life (24 to 36 months or longer). When you need to replace the batteries, always insist on the model fitted as standard equipment to your Supersport. If In doubt, consult with your local TGA authorized dealer.

14. TROUBLE SHOOTING

1. Your Supersport will not start:

- * Check it has not gone into sleep mode.
- * Make sure that the key switch is turned on. If it is, the battery condition gauge will be operating. If it is showing empty – recharge batteries.
- * Check overload switches
- * Check brake release is engaged

2. The battery condition gauge fails to operate when the key switch is in the on position, check the following:

- * Make sure the battery charger is not plugged to the wall outlet, this will prevent drive.
- * Check brake release is not disengaged.
- * Check the battery connectors, battery terminal condition.
- * If none of the above contact your Supersport Dealer.

3. If your Supersport does not slow down or the variable speed control does not work:

- * Turn off the power on key switch.
- * Inform your authorised TGA dealer.

4. The Supersport stops and will not restart.

- * Check the overload switch, which can be reset by simply push the button in (see 9.9. Safety Overload Switch).

CAUTION: If you find for any reason your Supersport does not reduce speed when you let go of the speed control lever, use the manual brake on the handlebars. If this fails to stop you, switch your Supersport off with the ON/OFF key. The parking brake will activate immediately and stop your Supersport. Beware the machine will stop very suddenly so brace yourself with the handlebars and sit back on your seat.

Care! Warning This operation should only be carried out as on emergency; continual use of this procedure will damage the drive transmission and motor brake. Consult your authorized TGA dealer before using your scooter again. If you feel for any reason that your Scooter is not driving correctly or making unusual noise, stop using the scooter. Be SAFE, contact your dealer, they will be able to advise you.

15. TECHNICAL SPECIFICATION

Dimensions	Supersport	
Length (with rear basket)	1750mm	69 ins
Length (without rear basket)	1500mm	59 ins
Width	690 mm	28 ins
Height (standard seat)	940 mm	37 ins
Height (deluxe seat)	1270 mm	50 ins
Height (for transport)	770 mm	30 ins
Weights:		
Without batteries	75 Kg	165 lbs
With 40A/H batteries	115 Kg	254 lbs
With 73A/H batteries	124 Kg	294 lbs
Speeds:		
Normal mode	6.4 kph	4 mph
Fast mode	12.8 kph	8 mph
Max Carrying Weight	160 Kg	352 lbs
Ground Clearance	120 mm	5 ins
Climbing Ability		
Max Slope angle (standard)	21%	
Max Slop angle (wide seat mod)	18%	
Obstacle Climbing	120 mm	5 ins
Turning Radius	1000 mm	39 ins
Tyre Size Front (Pneumatic)		2.75ins x 10ins
Tyre Size Rear (Pneumatic)		2.75ins x 14ins
Tyre Pressure (Front & Rear)	2-3 BAR	35 PSI
Approx Range:		
40A/H Batteries	Up to 32 km	Up to 20 miles
73A/H Batteries	Up to 48 km	Up to 30 miles

Supersport is manufactured in accordance with Safety Standard EN12184. It complies with CE Approval (Europe) and is approved by the TNO. TGA reserve the right to alter at any time without prior notice the design, specification, packaging or price of their products without incurring any obligation.

16. WARRANTY

This is to certify that your TGA product is warranted by TGA for a period of twelve months from the date of purchase subject to the following conditions:

1. This warranty is extended only to the original purchaser/user of the TGA product identified by the product serial number located on the frame. This warranty is not transferable.
2. TGA will repair or replace free of charge any part found upon inspection by an authorised representative of TGA to be defective in material and/or workmanship.
3. If a defect or fault is discovered, the dealer from where the product was purchased should be notified immediately.

Warranty Exclusions

- Tyres and the rear anti-tip wheels (these are normal wear components and replacement is not warranted)
- TGA will not be responsible for defects caused by abuse in return transit, vandalism, misuse, abuse, accident, negligence, alteration or misuse caused by non-observance of instructions set out in the Operators Manual
- This warranty does not cover commercial or rental use of the Supersport or any use other than normal.
- Upholstery and seating (these are normal wear components and replacement is not warranted)
- Returns are only accepted when the product is shipped in the original carton with original protective packing materials installed.
- Returned goods to be sent to TGA carriage paid. If a successful warranty claim is found TGA will pay return carriage. There is no other express warranty. Any and all other implied warranties are excluded. Your rights as a consumer are not affected.

Service Information: Only genuine TGA Spares should be used.

An authorised TGA dealer will service your Supersport under the terms of the above stated warranty. Servicing dealership personnel are trained professionals. They should be able to answer any question you may have. If you encounter a problem that a dealer does not solve to your satisfaction, please discuss it with the dealership's management. The Service Manager or General Manager can help. Almost all problems can be solved in this way. If you are dissatisfied with the decision made by the dealership's management, contact: TGA Electric Leisure Ltd.

17. SAFE DRIVING TIPS FOR SCOOTER USERS

Scoters fall into two categories, Class 2 which is essentially a 4mph pavement vehicle and can only legally be used on the road when either crossing over or because there are no footpaths. A Class 3 vehicle is capable of 4 & 8 mph and provided it is fitted with front and rear lights, flashing indicators, horn and rear view mirror it is legal for use on the road. It can also be used on the footpaths but must not exceed 4 mph. Class 2 & 3 vehicles must not be driven on Dual Carriageways, Motorways, Bus Lanes or Cycle Tracks.

INSURANCE

There is no legal requirement for insurance but it is a very good idea to have cover for fire and theft, accidental and malicious damage, and also third party damages. Just phone Karen at TGA (01787 882244) and she will talk you through it.

BREAKDOWN & GET YOU HOME SERVICE

Again a very good idea and can take a load of worry off your mind. Just talk to Karen.

MOBILE PHONE

An essential item if you are out there alone. You never know, breakdown, accident, health - communication is a must.

CARRYING LOADS

Do not overload. It may make the vehicle unstable and reduce its range. Place heavy loads inboard – in the middle – not behind the back wheel which can lighten the steering or can cause the front end to lift off the road on a bump, and not at the front which might make steering heavy.

WATCH YOUR BRAKES

Never try to drive, or even sit on your vehicle while it is in "free wheel". The electronic brake will be out of action and the vehicle could run away with you.

MAINTENANCE

Do carry out the checks listed in this manual regularly and also have the machine serviced at least once a year.

TYRES

Keep tyres at the pressure recommended by the manufacturer. They will last longer and be safer. Replace when they become worn.

LIGHTS

Check bulbs regularly and replace when needed, use your lights frequently, at dusk onwards, on a dull or rainy day. However, remember the use of lights may reduce the range of your scooter.

SENSIBLE GUIDELINES FOR SAFETY

When using the footpath

Just because you are on the footpath or pedestrian precinct does not make you a pedestrian. If you are on a motorized vehicle you are no longer a pedestrian.

Remember pedestrians always have right of way!

Many people on foot will be kind and helpful to the drivers of a wheelchair or scooter, but not everyone!

In a crowded precinct, market area, or footpath

It is your responsibility to ensure you do not run into anyone or do any harm with your vehicle. While many people will make way for you, you cannot expect **everyone** to do so. Some will appear to not even realize you are there. They will climb round and even over your vehicle rather than allow you room to move. Also be very aware of people's feet.

When climbing or descending kerbs

Always approach at right angles, with your front wheels straight on to the kerb. Do not climb or descend kerbs higher than the manufacturer recommends. Move carefully, to avoid traumatic bumps – to yourself or the vehicle.

Watch out for:

- Children – They may well run in front of you without warning. You may only be moving very slowly, but you could still injure a child.
- Elderly People – They may be unable to quickly move aside to let you pass. Give way to them
- Disabled people on foot – they too may be unable to dodge you
- People with visual problems or impaired hearing – Give them space and time
- Other motorised vehicle users – You may be doing all the right things. This does not guarantee they will do likewise

When you need help:

You may need to ask people to open doors for you

Most people are willing to help, if asked politely. Don't struggle to do the impossible, or even the very difficult things when there are people around who would help if asked.

Driving inside shops and buildings

This is where you have the advantage over car users! Not many supermarkets would welcome a car driving round their store. But most bigger shops and even some quite small ones, are accessible to wheelchairs and scooters. Once inside the store it is **your responsibility** to drive slowly and safely and not damage the fittings or the stock, or hurt other shoppers or store workers. You may need to ask for help. Again in most cases people are willing if asked properly. Don't risk pulling down a whole display to reach the top shelf. **ASK FOR HELP.**

Speed in shops and buildings

Reduce it! – It is a good idea to set the speed control to a lower level to avoid any accident. Be especially careful if you need to reverse, that your way is clear of shop fittings and people. Three wheeled scooters with their maneuverability and lightness of steering are more suited to shopping.

On the Road

Remember you are not driving a car, but a very small and slow vehicle, which is therefore more vulnerable.

If it is possible, use the footpath. It is wise to avoid using roads, particularly busy ones.

WHEN DRIVING YOUR VEHICLE ON THE ROAD:

Remember although this is legal for all Class 3 vehicles it is not always safe or sensible to do so. You are responsible for your own safety and that of other road users. The normal rules of the road apply and you must observe the law about:

- Driving on the left side of the road. Never drive against the traffic.
- One way streets – Never drive against the traffic
- Giving way where cars would give way (details in the Highway Code)
- Obeying traffic lights and all other road signals and instructions
- Giving way to pedestrians on crossings.

But always remember your vehicle is not a car and is small and vulnerable – If you need to turn right across traffic, try to get on to the footpath before the turn and then use a safe pedestrian crossing or traffic light control crossing. Only try to turn right if you are completely sure it is safe to do so. Do not rely only on your mirror. It may give a false impression of distance. Always give clear indication of intention to turn left or right.

Remember – the car you can see when you look behind may appear a long way away, but it is almost certainly moving faster than you are, often deceptively so. It could well be upon you before you complete your maneuver. And it may not be able to stop in time.

When passing a parked vehicle – take great care you are not moving into the path of a faster moving vehicle coming behind you, or towards you. Always signal your intention to pull out.

In the event of a difficult or dangerous situation – Use your hazard lights – But do not drive with them on unnecessarily



TGA Electric Leisure Ltd • Woodhall Business Park • Sudbury • Suffolk • CO10 1WH
T 01787 882244 • F 01787 882248
sales@tga-electric.com
www.tga-electric.com



TGA Electric Leisure Ltd reserves the right to change specification and/or prices without prior notification or warning
Supersport Handbook JULY 2008